

## MULTI SLAB CLAMP

PRODUCT CODE: APAC101008

WEIGHT: 8.0KG (17.6LBS)

SURFACE FINISH: HDG

DIMENSION: METRIC (MM)

COMPLIES WITH:

USA STANDARD: OSHA 1926.502(B);

EUROPEAN STANDARD: BS EN 13374:2004 (CLASS A);

CANADIAN STANDARD: OCCUPATIONAL HEALTH AND SAFETY ACT OF ONTARIO; ONTARIO REGULATION 213/91;

AUSTRALIAN /NEW ZEALAND STANDARD: AS/NZS 4994.1



### 1. Floor Slab Thickness $\leq 300$

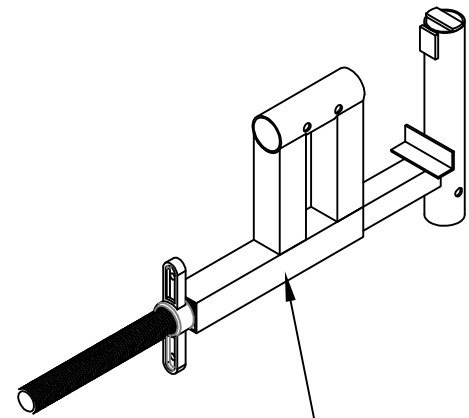
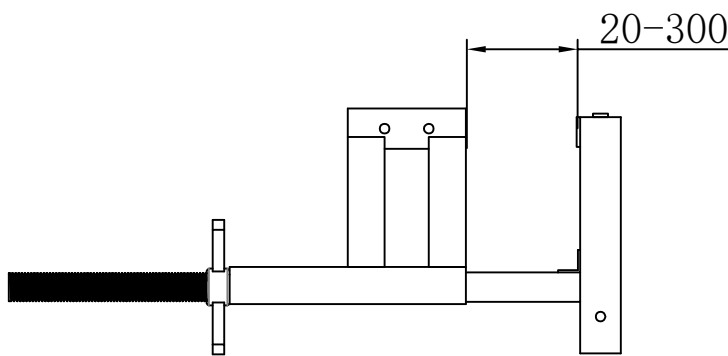

Adjust different directions according to the situation.

### 2. Floor Slab Thickness $\geq 300$

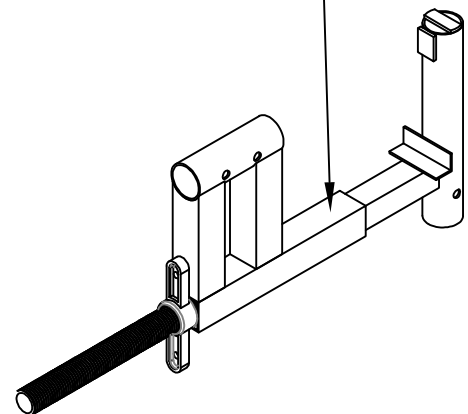
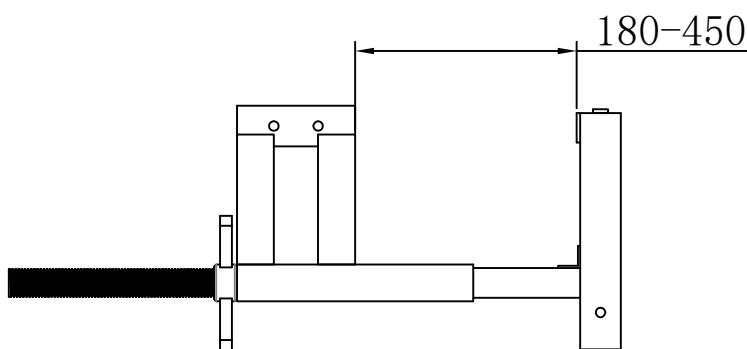

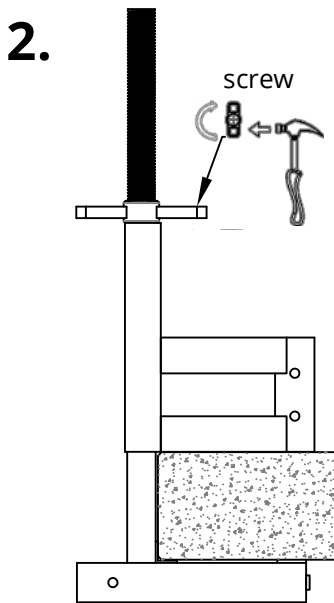
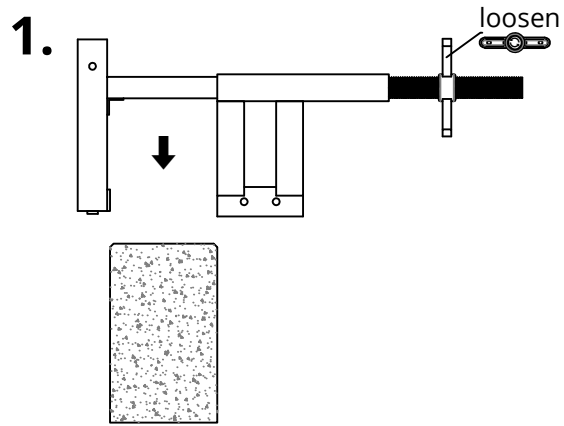
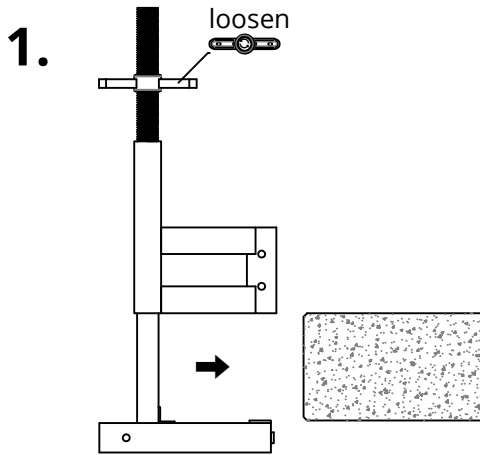

**\* Tighten the nut by hand and then hammer it to secure the clamp to the floor**

