



Slab Grabber

PRODUCT CODE: APAC101009

WEIGHT: 8.55KG (18.85LBS)

SURFACE FINISH: ELECTRO-GALVANIZED

DIMENSION: METRIC (MM)

COMPLIES WITH:

USA STANDARD: OSHA 1926.502(B);

EUROPEAN STANDARD: BS EN 13374:2004 (CLASS A);

CANADIAN STANDARD: OCCUPATIONAL HEALTH AND SAFETY ACT OF ONTARIO; ONTARIO REGULATION 213/91;

AUSTRALIAN /NEW ZEALAND STANDARD: AS/NZS 4994.1

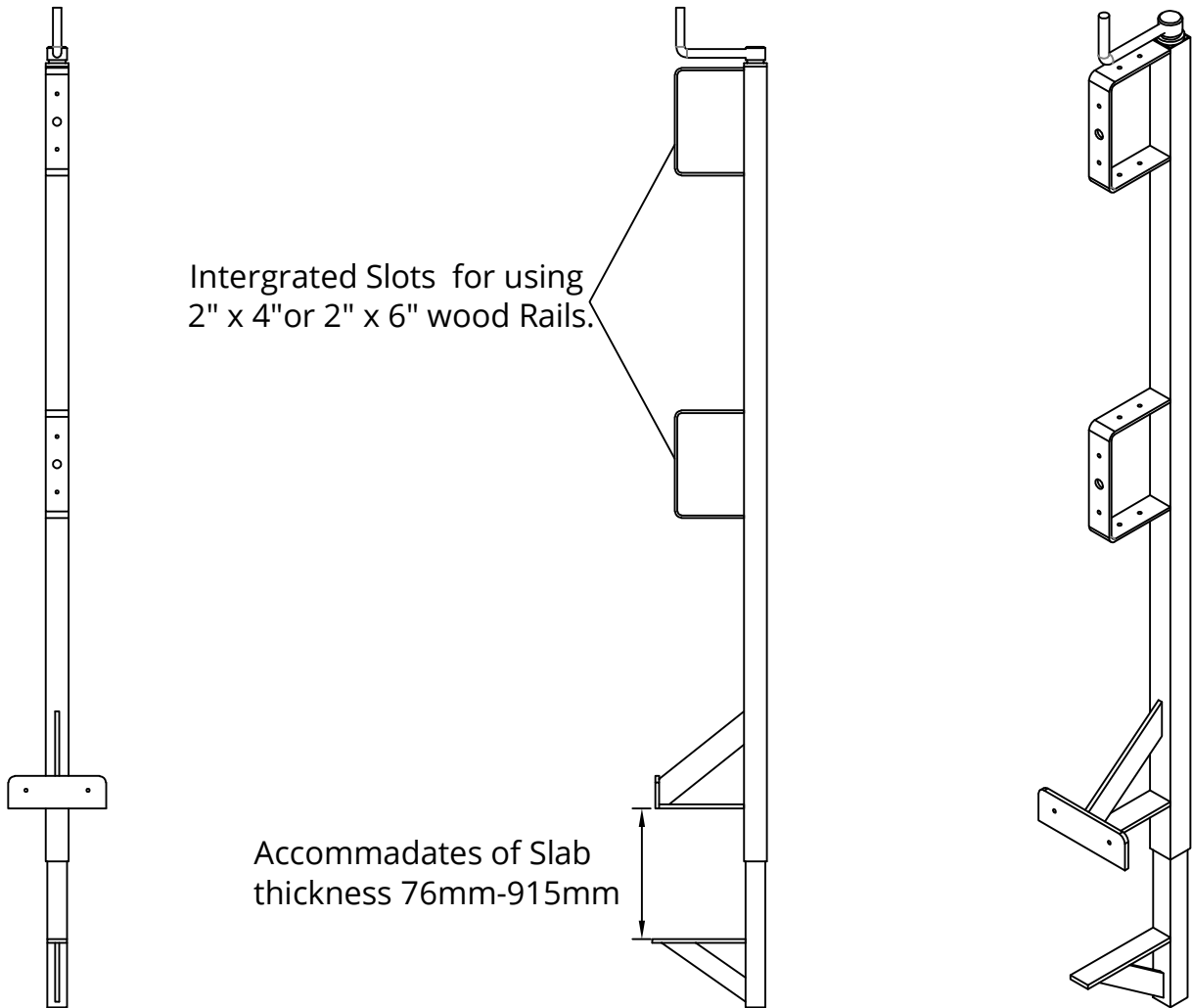

1. Turn the handle counterclockwise to loosen inner tube below

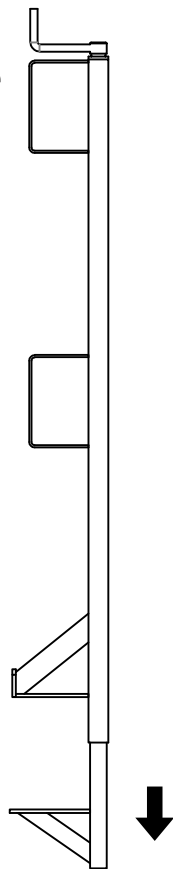

2. Turn the handle clockwise to screw inner tube below

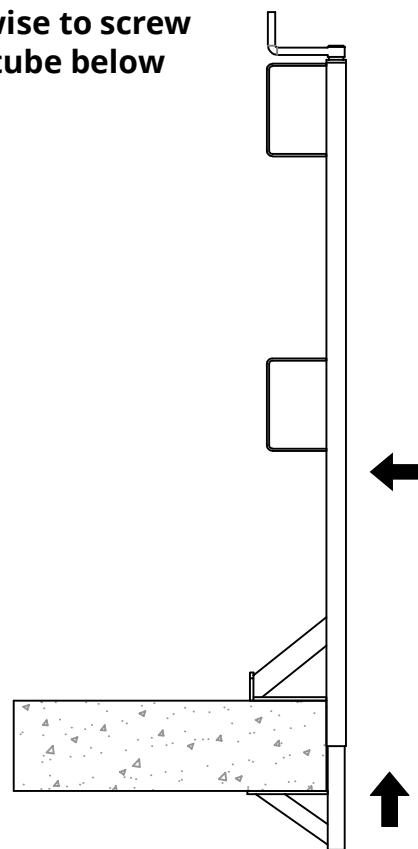

3. Insert board

